

FEDERAL SUPPLY CLASS  
5306

REV.  
C

RATIONALE

ALTERNATIVE SILVER PLATE SPEC ADDED, SPECS UPDATED, USAGE OF PARTS NOTE ADDED.

NOTICE

THE INITIAL SAE PUBLICATION OF THIS DOCUMENT WAS TAKEN DIRECTLY FROM U.S. MILITARY STANDARD MS9715A, AMENDMENT 1. THIS SAE STANDARD MAY RETAIN THE SAME PART NUMBERS ESTABLISHED BY THE ORIGINAL MILITARY DOCUMENT.

ANY REQUIREMENTS ASSOCIATED WITH QUALIFIED PRODUCTS LISTS (QPL) MAY CONTINUE TO BE MANDATORY FOR DOD CONTRACTS. REQUIREMENTS RELATING TO QPL'S HAVE NOT BEEN ADOPTED BY THE SAE FOR THIS STANDARD AND ARE NOT PART OF THIS SAE DOCUMENT.

SAE Technical Standards Board Rules provide that: "This report is published by SAE to advance the state of technical and engineering sciences. The use of this report is entirely voluntary, and its applicability and suitability for any particular use, including any patent infringement arising therefrom, is the sole responsibility of the user." SAE invites your written comments and suggestions. SAE reviews each technical report at least every five years at which time it may be revised, reaffirmed, stabilized, or cancelled.

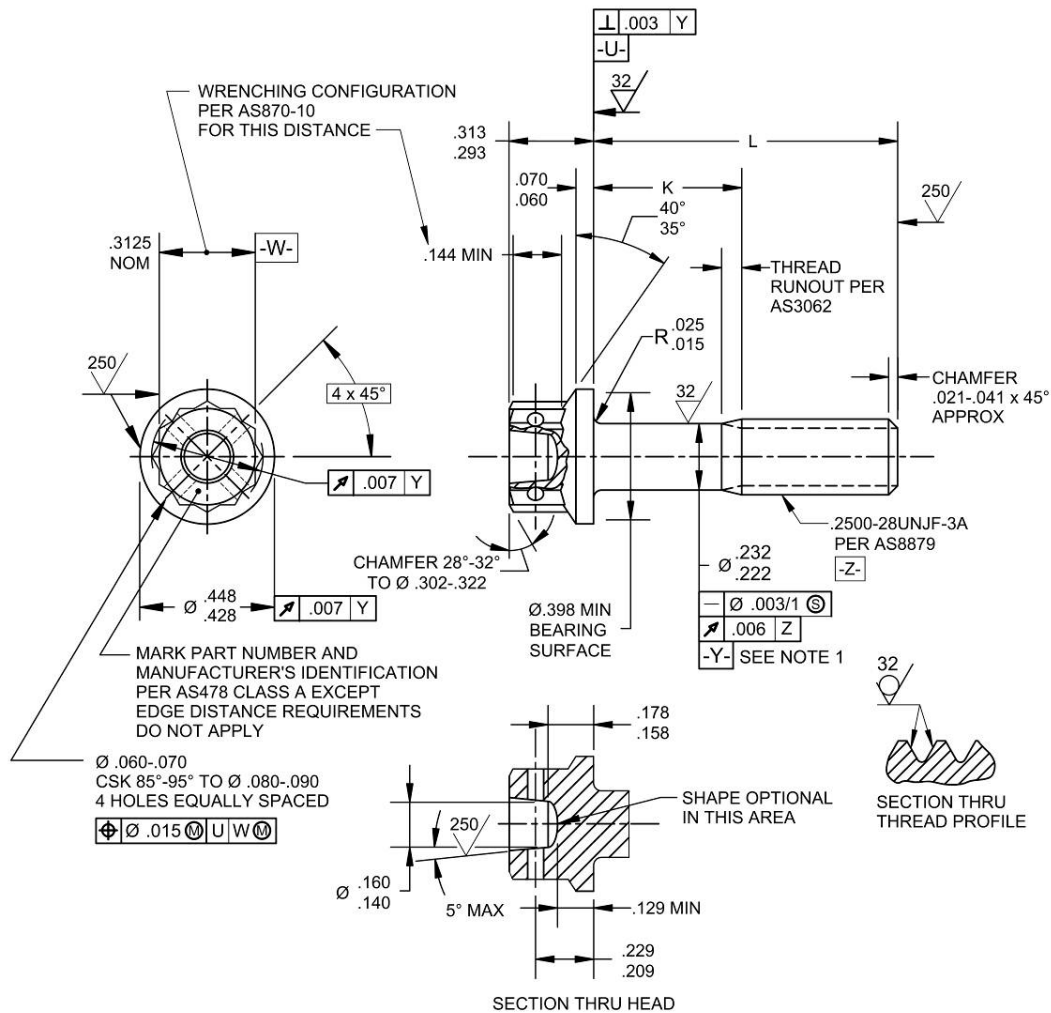
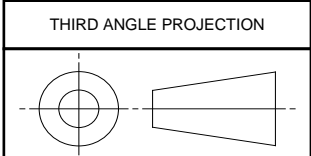

FIGURE 1 - BOLT

SAE values your input. To provide feedback on this Technical Report, please visit <http://standards.sae.org/AS9715C>



CUSTODIAN: E-25

PROCUREMENT SPECIFICATION: AS7471



**AEROSPACE STANDARD**

BOLT, MACHINE-DOUBLE HEXAGON, EXTENDED WASHER HEAD, DRILLED, SILVER PLATED, CORROSION AND HEAT RESISTANT NICKEL ALLOY, .2500-28 UNJF-3A

AS9715™  
SHEET 1 OF 3

REV.  
C

ISSUED 1998-10 REAFFIRMED 2003-10 REVISED 2018-03